

MODEL

AG STOP GATES



GENERAL DESCRIPTION

The ORBINOX model AG Stop Gate is designed for open channel installation in waste water treatment plants, irrigation, hydraulic works and hydro-electric power plants. They are used to isolate other equipment for maintenance, repairs or inspection.

The slide is hand operated or hoist operated for larger sizes. The sealing system is incorporated on both laterals and bottom area of the slide, resulting in a substantially watertight seal without the need of wedges on the gate. From sizes 6" x 6" (150mm x 150mm) to 140" x 140" (3500mm x 3500mm), the AG model has a self-adjusting seal design with low leakage performance. The leakage rate on the ORBINOX stop gate is lower than the maximum allowable recommended by AWWA (C561) under normal conditions.

The frame of the AG model is typically embedded in a concrete channel for both uni-directional (seating head only) or bi-directional sealing (seating and unseating water head). ORBINOX can also offer different mounting options such as wall mount and existing channel mount where required. Our engineering team can also design and manufacture the AG Stop Gate in larger dimensions and for higher service conditions while maintaining a leakage rate below the allowable standard from AWWA. For more information, please contact an ORBINOX representative.



CONSTRUCTION DESIGN

The standard AG model is manufactured in stainless steel which has a higher corrosion resistance in many applications which results in a higher life cycle with little or no maintenance. Other materials of construction are available upon request, such as AISI 904L, Duplex stainless, etc.

MODEL

AG STOP GATES



DESIGN FEATURES

- Stainless steel fabricated modular design (corrosion resistance)
- Mounting options: Embedded In Concrete, Wall Mount and Face Mount In Existing Channel
- Option of Uni-Directional and Bi-Directional sealing
- The slide is designed to seal at the bottom due to its own weight
- ORBINOX Stop Gates are completely factory assembled and tested eliminating the need for on site adjustment
- UHMWPE guides reduce the friction coefficient during operation, minimizing therefore the required pull-out thrust and extending the seal life
- Self adjusting seal design (wedges not required)
- Stainless steel fasteners on ORBINOX slide gates

Allowable Leakage:

The leakage rate on the model AG is lower than the maximum allowable recommended by AWWA under normal conditions for both seating and unseating head pressures.

- AWWA standard leakage rate: 0.1 USGPM per foot of perimeter (1.24 l/min per meter)
- ORBINOX standard leakage rate: 0.05 USGPM per foot of perimeter (0.62 l/min per meter)

Seating and Unseating Design Head:

The AG model is designed to withstand a water pressure equal to the height of the slide. The uni-directional AG Stop Gate is very appropriate for on-seating head pressure conditions, offering a very economical solution. The bidirectional AG Stop Gate is designed for both off and on-seating normal head pressure conditions.

Seal design:

The AG model has a unique seal design. The self-adjusting "lip-design" side seals ensure a substantially watertight performance. The design allows the EPDM seals to be installed on the slide leaving the opening unobstructed when the gate is in the open position. It also allows easy access to reverse or replace the bottom seal or change the side seals if damaged, resulting in cost savings in maintenance time. The HMWPE guides and bearings ensure no metal-to-metal contact between the frame and slide which reduces the friction during operation and extends seal life.

Seal Design: AG Uni-Directional and Embedded In Concrete

SIDE SEAL

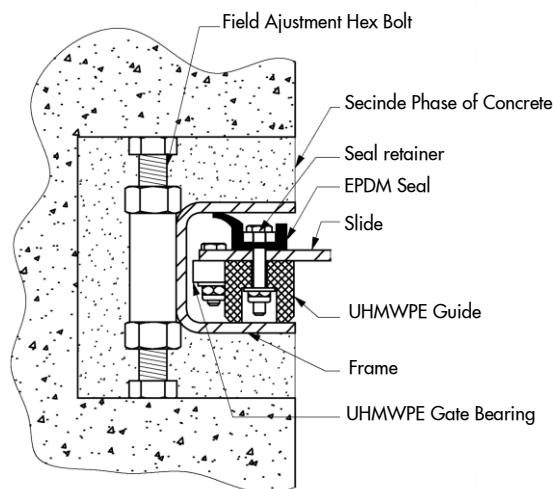

BOTTOM SEAL

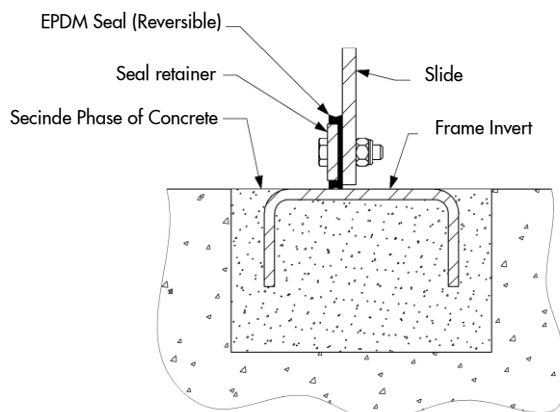

ООО «ТИ-СИСТЕМС» ИНЖИНИРИНГ И ПОСТАВКА ТЕХНОЛОГИЧЕСКОГО ОБОРУДОВАНИЯ

Интернет: www.tisys.ru www.tisys.kz www.tisys.by www.tesec.ru www.ти-системс.пф

Телефоны: +7 (495) 7774788, 7489626, (925) 5007155, 54, 65 Эл. почта: info@tisys.ru info@tisys.kz info@tisys.by

MODEL

AG STOP GATES



DESIGN FEATURES

Seal Design: AG Bi-Directional and Embedded In Concrete

SIDE SEAL

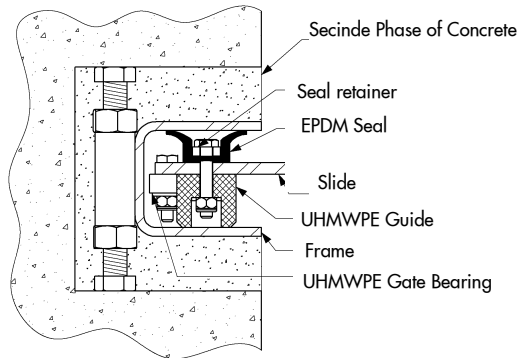

BOTTOM SEAL

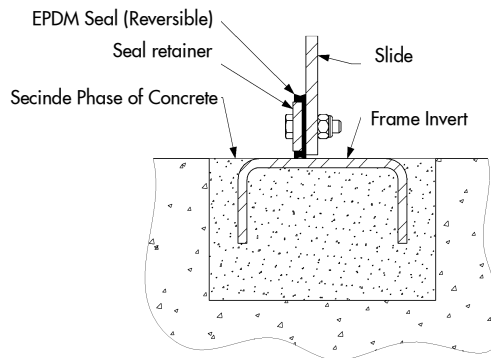

Seal Design: AG Bi-Directional and Wall Mounted (Uni-Directional optional)

SIDE SEAL

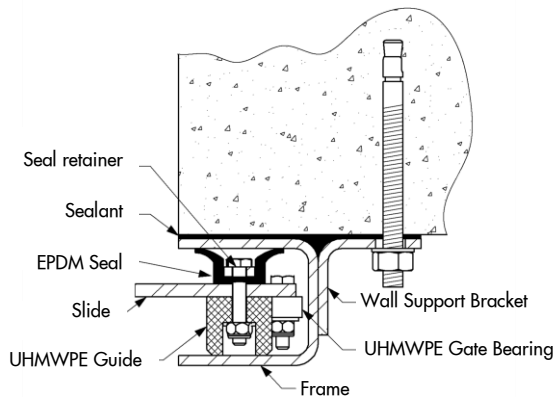

BOTTOM SEAL

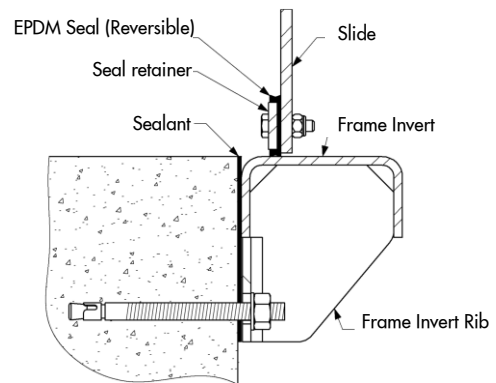

Seal Design: AG Bi-Directional and Existing Channel (Uni-Directional optional)

SIDE SEAL

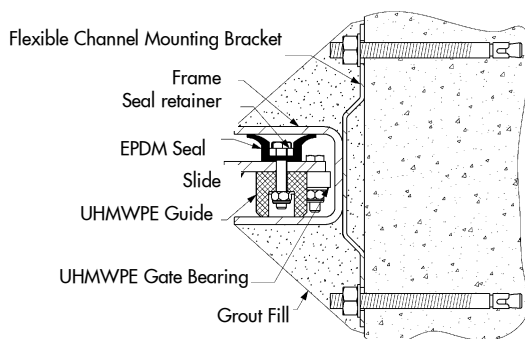

BOTTOM SEAL

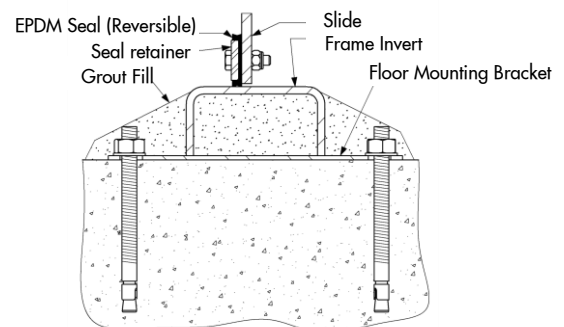

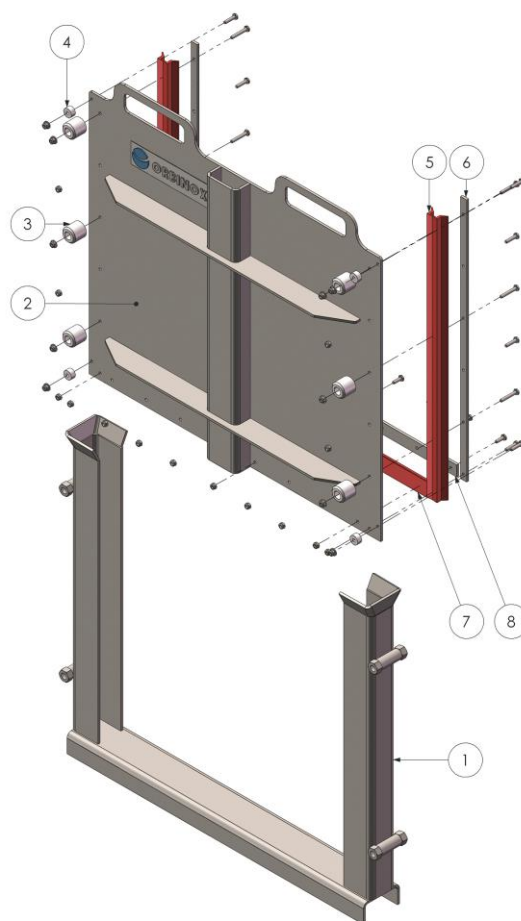
MODEL**AG STOP GATES****STANDARD MATERIALS OF CONSTRUCTION**

ITEM	DESCRIPTION	MATERIAL
1	Frame	Stainless Steel ASTM A-240 / Type 304L or 316L
2	Slide	Stainless Steel ASTM A-240 / Type 304L or 316L
3	Guides	Ultra High Molecular Weight Polyethylene (UHMWPE) ASTM D-4020
4	Gate Bearings	Ultra High Molecular Weight Polyethylene (UHMWPE) ASTM D-4020
5	Seal	EPDM
6	Seal retainer	Stainless Steel ASTM A-240 / Type 304L or 316L
7	Bottom Seal	EPDM
8	Bottom Seal Retainer	Stainless Steel ASTM A-240 / Type 304L or 316L

*Note: for materials other than the above, please contact an ORBINOX representative

MODEL

AG STOP GATES



MOUNTING OPTIONS

The following drawings show the most common mounting options for AG Stop Gates. For other mounting options please contact an ORBINOX representative.

EMBEDDED IN CONCRETE (EC)

Model: AG-EC

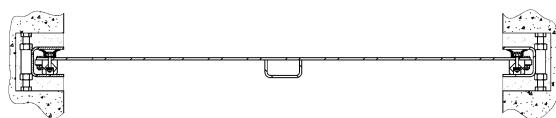

WALL MOUNTED (WM)

Model: AG-WM

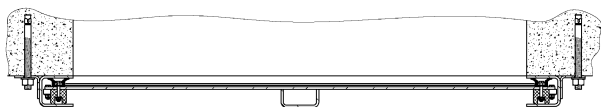

FACE MOUNTED IN EXISTING CHANNEL (FM)

Model: AG-FM

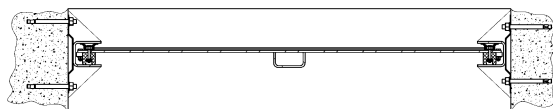

LIFTING MECHANISM

In order to lift the slide, ORBINOX can design different lifting mechanisms. For the smaller sizes, the slide is lifted manually with the help of a hook. For larger gates, it can be designed to be lifted using an overhead hoist.

Lifting Device

When required, a stainless steel lifting device can be supplied. The lifting device fits into the frame and hooks and releases the logs automatically using a spring mechanism.

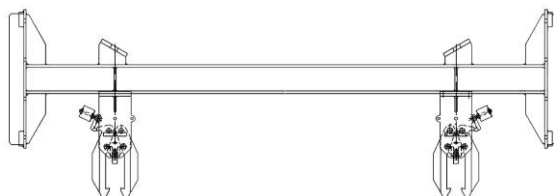

MODEL

AG STOP GATES



INSTALLATION, OPERATION AND MAINTENANCE (IOM)

This section briefly describes the installation, operation and maintenance of AG Stop Gates. For more detailed information please refer to the IOM Manual

Installation:

A) Embedded in Concrete (EC): field adjusting bolts are supplied to center the gate frame in the appropriate recess prior to embedding in concrete

B) Wall Mount (WM): the AG Stop Gate is installed by means of mechanical anchor bolts (Hilti Kwilt 3 or equivalent) and construction sealant (Sikabond or equivalent)

C) Face Mounted in Existing Channel (FM): the AG Stop Gate is installed by means of mechanical anchor bolts (Hilti Kwilt 3 or equivalent). All the gaps shall be grout filled afterwards and shaped in order to assure a smooth transition

The minimum concrete strength shall be 3,000 PSI (20.7 MPa). The tolerance of the concrete construction (flatness, levelness and plumbness) shall be in accordance to ACI 117-10 standard or equivalent DIN 18202 std.

For detailed information about the type, size and quantity of the required anchor bolts or other installation materials, please refer to the notes on the "General Arrangement Drawing".

Maintenance and Operation:

The ORBINOX AG Stop Gates need practically no maintenance. Seals should be replaced if damaged.

MODEL

AG STOP GATES



AG-EC · BI-DIRECTIONAL · DIMENSIONS

The following drawings show the most common mounting options, as well as the respective dimensional charts.

SIZES: 6" x 6" (150mm x 150mm) to 140" x 140" (3500mm x 3500mm)

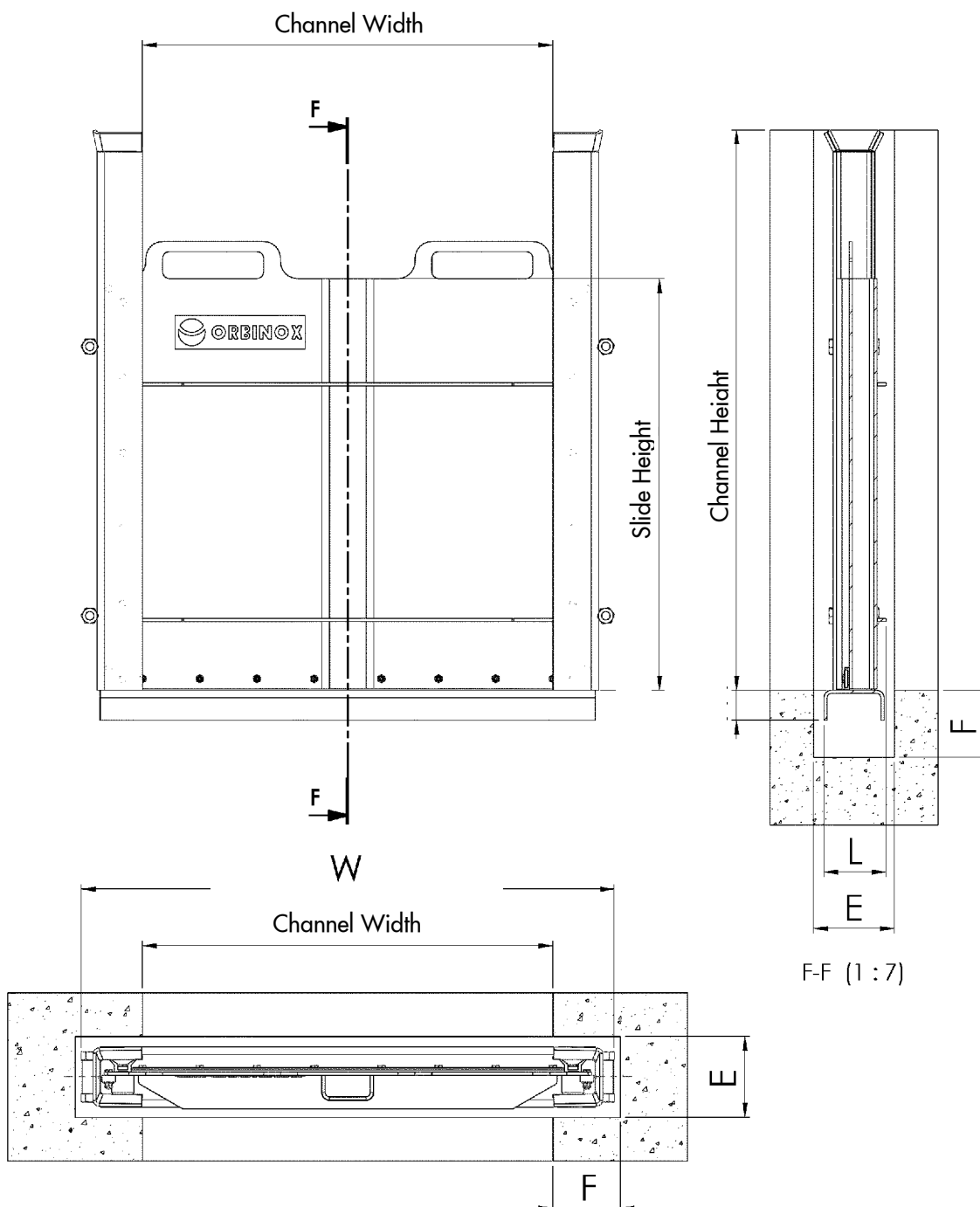

MODEL**AG STOP GATES****AG-EC · BI-DIRECTIONAL · DIMENSIONS****SIZES: 6" x 6" (150mm x 150mm) to 140" x 140" (3500mm x 3500mm)**

SIZE Channel Width	SIZE Slide Height	W	L	H1	E x F
6"	6"	13 1/16	3 9/16	1 3/4	4 3/4 x 3 15/16
8"	8"	15 1/16	3 9/16	1 3/4	4 3/4 x 3 15/16
12"	12"	19 1/16	3 9/16	1 3/4	4 3/4 x 3 15/16
16"	16"	23 1/16	3 9/16	1 3/4	4 3/4 x 3 15/16
20"	20"	27 1/16	3 9/16	1 3/4	4 3/4 x 3 15/16
24"	24"	31 1/16	3 9/16	1 3/4	4 3/4 x 3 15/16
28"	28"	35 1/16	3 9/16	1 3/4	4 3/4 x 3 15/16
32"	32"	39 1/16	3 9/16	1 3/4	4 3/4 x 3 15/16
36"	36"	43 1/16	3 9/16	1 3/4	4 3/4 x 3 15/16
40"	40"	47 1/16	3 5/16	1 3/4	4 3/4 x 3 15/16
44"	44"	51 1/16	4 5/16	2 9/16	9 3/16 x 3 15/16
48"	48"	55 1/16	4 5/16	2 9/16	9 3/16 x 3 15/16
52"	52"	59 1/16	4 5/16	2 9/16	9 3/16 x 3 15/16
56"	56"	63 1/16	4 5/16	2 9/16	9 3/16 x 3 15/16
60"	60"	67 5/8	5 1/2	4	9 3/16 x 3 15/16
64"	64"	71 5/8	5 1/2	4	9 3/16 x 3 15/16
68"	68"	75 5/8	5 1/2	4	9 3/16 x 3 15/16
72"	72"	79 5/8	5 1/2	4	9 3/16 x 3 15/16
76"	76"	83 5/8	5 1/2	4	9 3/16 x 3 15/16
80"	80"	87 5/8	5 1/2	4	9 3/16 x 3 15/16
100"	100"	107 3/4	5 1/2	4 3/4	9 3/16 x 3 15/16
120"	120"	127 3/4	5 1/2	4 3/4	12 x 6
140"	140"	147 3/4	5 1/2	4 3/4	12 x 6

Note: for dimensions other than above, please contact an ORBINOX representative
 These dimensions are for information only. Do not use for installation or submittal purposes

MODEL

AG STOP GATES



AG-WM· BI-DIRECTIONAL · DIMENSIONS

SIZES: 6" x 6" (150mm x 150mm) to 140" x 140" (3500mm x 3500mm)

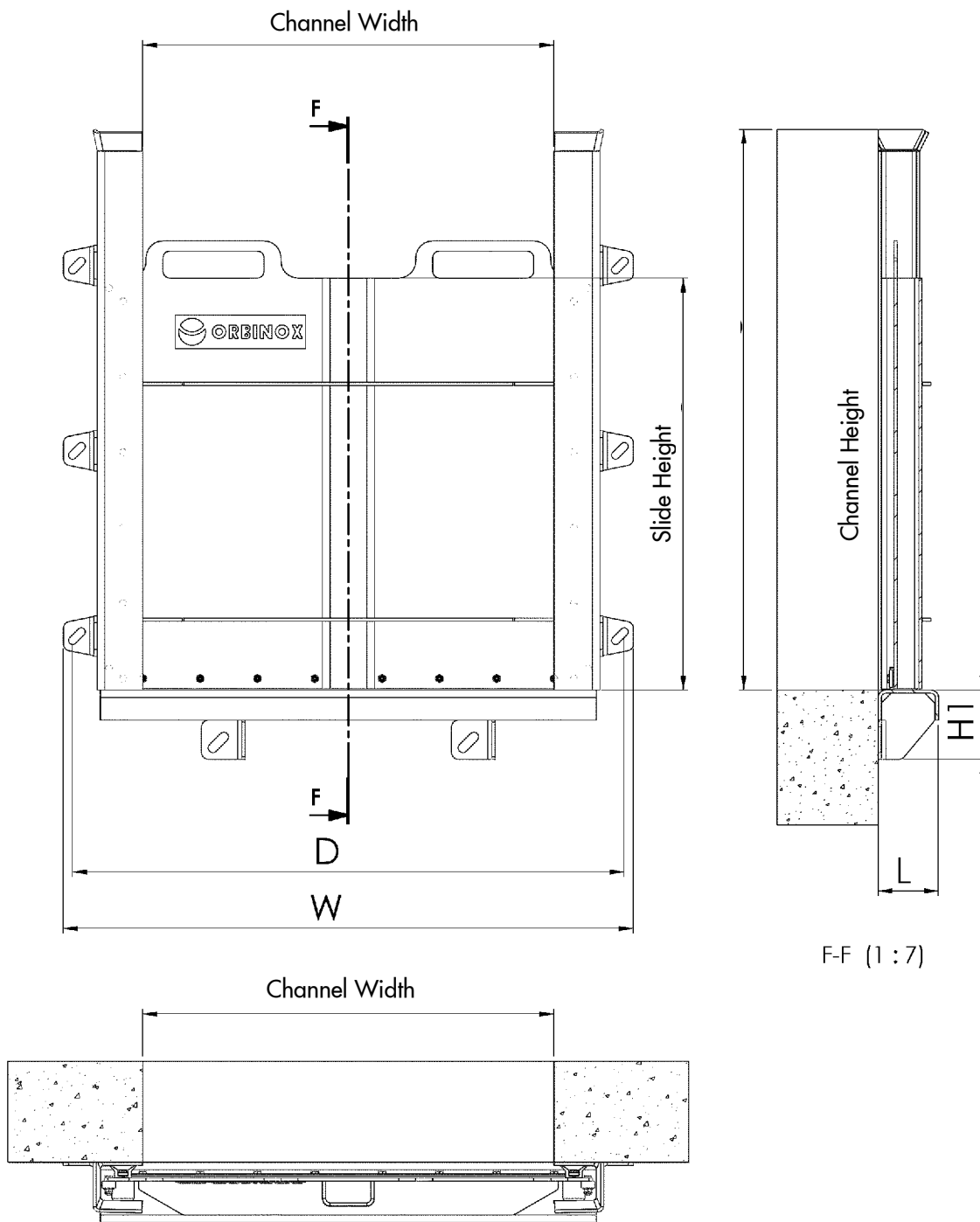

MODEL**AG STOP GATES****AG-WM· BI-DIRECTIONAL · DIMENSIONS****SIZES: 6" x 6" (150mm x 150mm) to 140" x 140" (3500mm x 3500mm)**

SIZE Channel Width	SIZE Slide Height	W	D	L	H1
6"	6"	15 1/4	13 5/16	3 9/16	4 1/16
8"	8"	17 3/4	15 5/16	3 9/16	4 1/16
12"	12"	21 1/4	19 5/16	3 9/16	4 1/16
16"	16"	25 1/4	23 5/16	3 9/16	4 1/16
20"	20"	29 1/4	27 5/16	3 9/16	4 1/16
24"	24"	33 1/4	31 5/16	3 9/16	4 1/16
28"	28"	37 1/4	35 5/16	3 9/16	4 1/16
32"	32"	41 1/4	39 5/16	3 9/16	4 1/16
36"	36"	45 1/4	43 5/16	3 9/16	4 1/16
40"	40"	49 1/4	47 5/16	3 9/16	4 1/16
44"	44"	53 1/4	51 5/16	4 5/16	4 1/8
48"	48"	57 1/4	55 5/16	4 5/16	4 1/8
52"	52"	61 1/4	59 5/16	4 5/16	4 1/8
56"	56"	65 1/4	63 5/16	4 5/16	4 1/8
60"	60"	69 13/16	67 7/8	5 1/2	6 1/4
64"	64"	73 13/16	71 7/8	5 1/2	6 1/4
68"	68"	77 13/16	75 7/8	5 1/2	6 1/4
72"	72"	81 13/16	79 7/8	5 1/2	6 1/4
76"	76"	85 13/16	83 7/8	5 1/2	6 1/4
80"	80"	89 13/16	87 7/8	5 1/2	6 1/4
100"	100"	112	110	5 1/2	6 1/4
120"	120"	132	130	5 1/2	6 1/4
140"	140"	152	150	5 1/2	6 1/4

Note: for dimensions other than above, please contact an ORBINOX representative

These dimensions are for information only. Do not use for installation or submittal purposes

ООО «ТИ-СИСТЕМС» ИНЖИНИРИНГ И ПОСТАВКА ТЕХНОЛОГИЧЕСКОГО ОБОРУДОВАНИЯ

Интернет: www.tisys.ru www.tisys.kz www.tisys.by www.tesec.ru www.ти-системс.рф

Телефоны: +7 (495) 7774788, 7489626, (925) 5007155, 54, 65 Эл. почта: info@tisys.ru info@tisys.kz info@tisys.by

MODEL

AG STOP GATES



AG-FM · BI-DIRECTIONAL · DIMENSIONS

SIZES: 6" x 6" (150mm x 150mm) to 140" x 140" (3500mm x 3500mm)

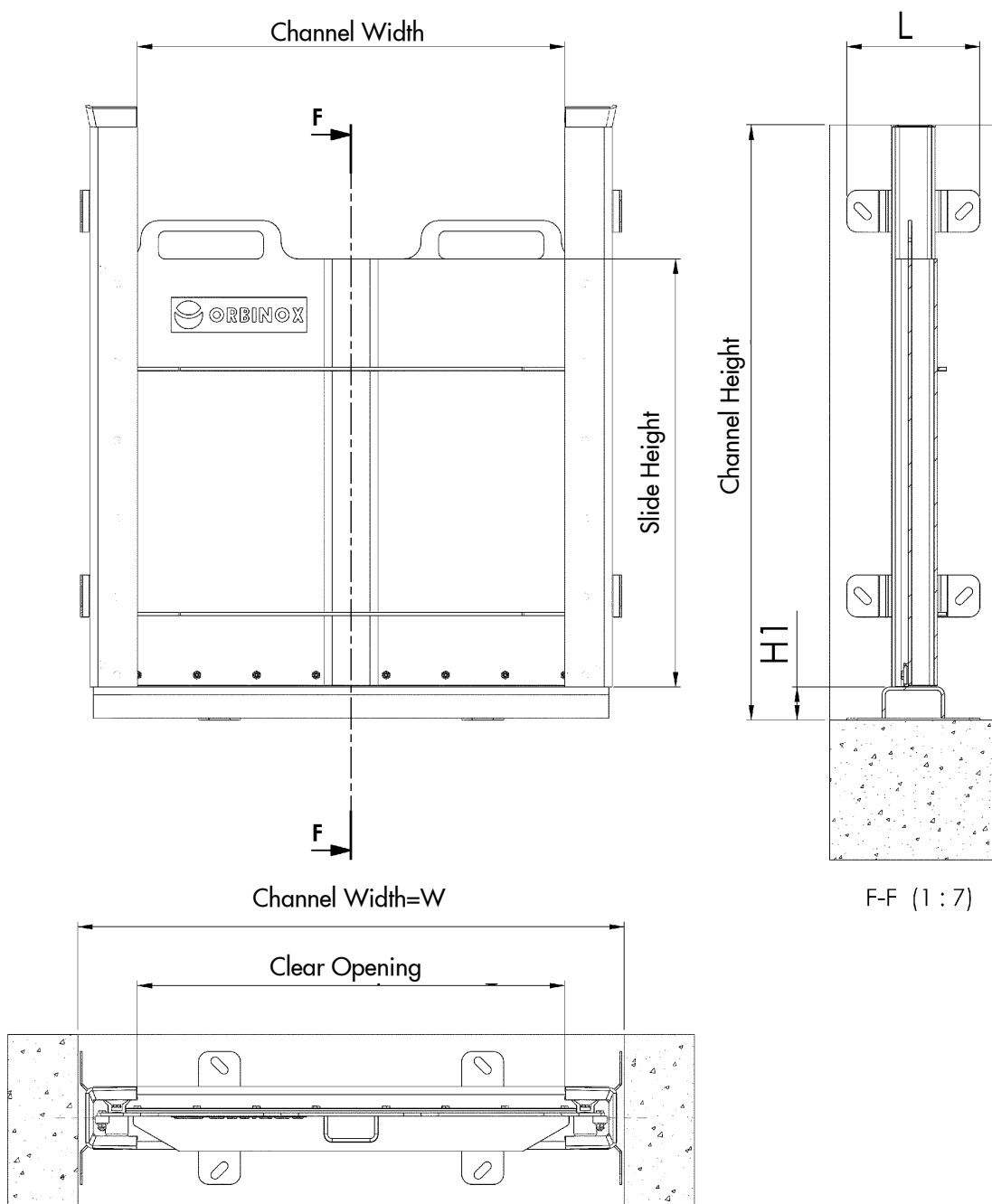

MODEL**AG STOP GATES****AG-FM · BI-DIRECTIONAL · DIMENSIONS****SIZES: 6" x 6" (150mm x 150mm) to 140" x 140" (3500mm x 3500mm)**

SIZE Channel Width	SIZE Slide Height	W	Clear Opening	L	H1
6"	6"	6	5/16	7 1/2	1 15/16
8"	8"	8	2 5/16	7 1/2	1 15/16
12"	12"	12	6 5/16	7 1/2	1 15/16
16"	16"	16	10 5/16	7 1/2	1 15/16
20"	20"	20	14 5/16	7 1/2	1 15/16
24"	24"	24	18 5/16	7 1/2	1 15/16
28"	28"	28	22 5/16	7 1/2	1 15/16
32"	32"	32	26 5/16	7 1/2	1 15/16
36"	36"	36	30 5/16	7 1/2	1 15/16
40"	40"	40	34 5/16	7 1/2	1 15/16
44"	44"	44	38 5/16	7 1/2	2 1/2
48"	48"	48	42 5/16	7 1/2	2 1/2
52"	52"	52	46 5/16	7 1/2	2 1/2
56"	56"	56	50 5/16	7 1/2	2 1/2
60"	60"	60	53 11/16	8 7/8	4 1/16
64"	64"	64	57 11/16	8 7/8	4 1/16
68"	68"	68	61 11/16	8 7/8	4 1/16
72"	72"	72	65 11/16	8 7/8	4 1/16
76"	76"	76	69 11/16	8 7/8	4 1/16
80"	80"	80	73 11/16	8 7/8	4 1/16
100"	100"	100	90	8 7/8	4 1/16
120"	120"	120	110	8 7/8	4 1/16
140"	140"	140	130	8 7/8	4 1/16

Note: for dimensions other than above, please contact an ORBINOX representative
 These dimensions are for information only. Do not use for installation or submittal purposes

MODEL

AG STOP GATES



STANDARD SPECIFICATION

Model AG Stop Gate 6" x 6" - 140" x 140" (150mm x 150mm - 3500mm x 3500mm)

GENERAL CONDITIONS

The equipment provided under this section shall be fabricated, assembled, erected, and placed in proper operating condition in full conformity with the drawings, specifications, engineering data, instructions and recommendations of the equipment manufacturer unless exceptions are noted by the engineer. Gates and operators shall be supplied with all the necessary parts and accessories indicated on the drawings, specified or otherwise required for a complete, properly operating installation, and shall be the latest standard product of a manufacturer regularly engaged in the production of fabricated gates. Gates supplied under this section shall be Model AG Stainless Steel Stop Gates as manufactured by ORBINOX.

QUALITY ASSURANCE. The manufacturer shall have experience in the production of substantially similar equipment, and shall show evidence of satisfactory operation in at least 50 installations. The manufacturer's shop welds, welding procedures and welders shall be qualified and certified in accordance with the requirement of the latest edition of ASME, Section IX.

SUBMITTALS. The manufacturer shall submit for approval by the purchaser, drawings showing the principal dimensions, general construction and materials used in the gate.

PERFORMANCE

LEAKAGE. Stop Gates shall be substantially watertight under the design head conditions. Under the design seating head, the leakage shall be 0.05 U.S. gallon per minute per foot (0.62 l/min per meter) of seating perimeter or better.

DESIGN HEAD. The channel gate shall be designed to withstand the design head shown in the schedule.

PRODUCT (STOP GATE)

GENERAL DESIGN. Gates shall be non self-contained (open frame) as indicated on the gate schedule. All components of the gate shall be designed to withstand the maximum head indicated on the drawings in both seating and unseating directions.

FRAME. The gate frame shall be constructed of structural members or formed plate welded to form a rigid one-piece frame. The frame shall be suitable for mounting embedded in concrete (EC), wall mounted (WM) or face mounted in a existing channel (FM).

The frame configuration shall be of the flush-bottom type and shall allow the replacement of the seals without removing the gate frame from the concrete. The design stress shall not exceed the lesser of 50% of the yield strength or 25% of the ultimate strength of the materials for maximum load conditions.

SLIDE. The slide shall consist of a flat plate reinforced with formed plates or structural members to limit its deflection to 1/720 of the gate's span under the design head or 1/16", whichever is less. The minimum thickness of the slide shall be 1/4". The design stress shall not exceed the lesser of 50% of the yield strength or 25% of the ultimate strength of the materials for maximum load conditions.

GUIDES, BEARINGS AND SEALS. The guides and bearings shall be of UHMWPE (ultra high molecular weight polyethylene). Side seals shall be of EPDM and the design shall be of the self-adjusting lip design. Wedging devices are not acceptable. The seat system shall maintain efficient sealing in any position of the slide and allow the water to flow only in the opened part of the gate, as long as the water level is below the height of the slide. The bottom seal shall be made of resilient EPDM set onto the bottom member of the slide and shall be replaceable without removing the gate frame from the wall or channel.

MODEL**AG STOP GATES**

STANDARD SPECIFICATION

MATERIALS

Part	Material
Frame, Slide, Seal Retainer and Yoke	Stainless Steel ASTM A-240 /Type 304L or 316L
Guides and Front Guides	Ultra High Molecular Weight Polyethylene (UHMWPE) ASTM D-4020
Side Seal and Bottom Seal	EPDM
Hardware	ASTM F593 and F594 GR1 for 304L Frame and GR2 for 316L Frame

SCHEDULE

Gate Identification

Size (Channel Width x Slide Height)

Invert Elevation

Operating Floor Elevation

Seating Head

Unseating Head

Mounting Type

- EC: Embedded in Concrete
 - WM: Wall Mounted
 - FM: Face Mounted (In a Existing Channel)
-

EXECUTION

INSTALLATION:

Gates and appurtenances shall be handled and installed in accordance with the manufacturer's recommendations

MODEL

AG STOP GATES



AG STOP GATE SELECTION FORM

Customer: _____ Tag No.: _____ Date: _____

Order Number: _____ Qty.: _____

STOP GATE DESIGN (Size= Channel Width x Slide Height)

Units: mm inch

Channel Width _____ Channel Height _____

Slide Height _____

Seating Water Head: _____

Unseating Water Head: _____

Uni-Directional

Bi-Directional

STOP GATE MOUNTING

Embedded in Concrete (a)

Face Mounted In Existing Channel (b)

Wall Mounted (c)

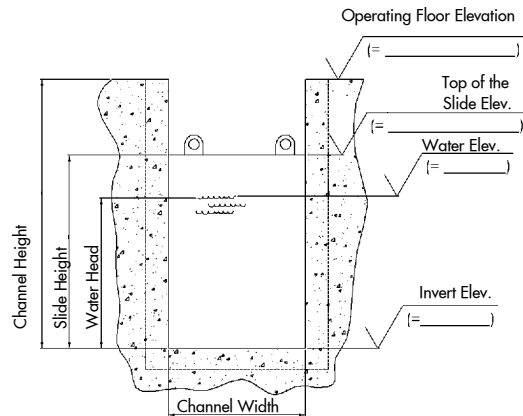
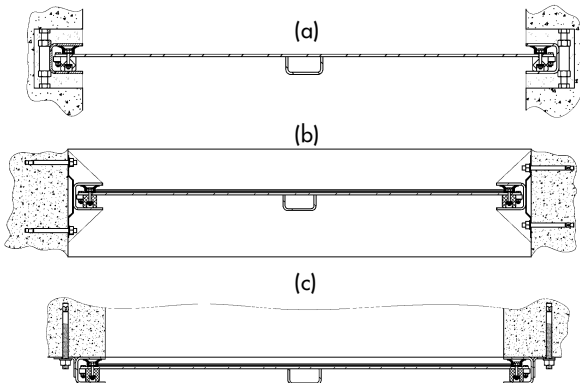

. Slide Height=Top of the Slide - Invert Level

(As standard: Silde Height=Water Head + 6" (150 mm)

. Channel Height=Operating Floor Level-Invert Level

. Water Head=Water Level- Invert Level

Frame Invert Mounting:

Embedded in Concrete

Face Mounted In Existing Channel

Wall Mounted

LIFTING MECHANISM

Hand pull

Prepared for external crane

Lifting device (c)

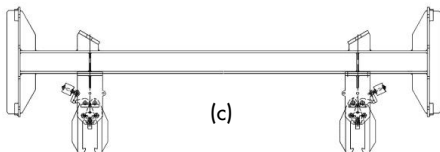

MATERIALS

Frame&Slide: 304L SS 316L SS Other: _____

Seal: EPDM Other: _____

REMARKS

Name: _____

Signature: _____